

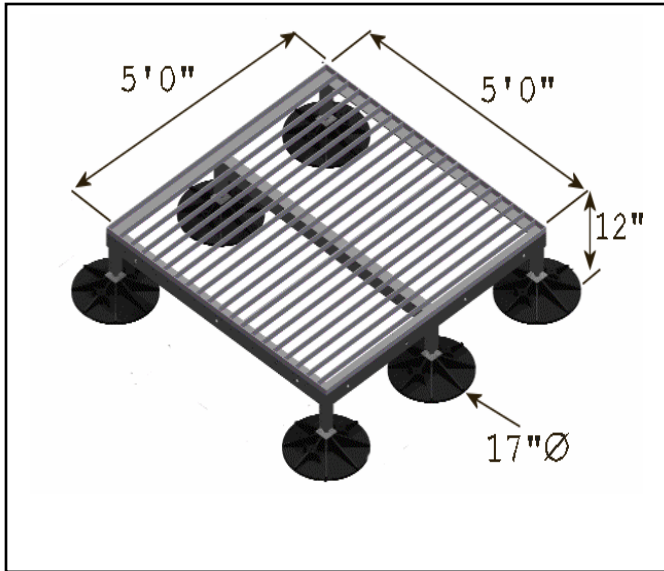

# HV0505B

## Base Platform

## Specification Sheet



**HV0505B – Base Platform** – Is designed specifically for use on rooftop without adhesive, roof penetrations, flashings or damage to roofing system. Designed to support HVAC units or transformers. Base Platform is expandable on all sides. The height of the platform is adjustable to 12" H with adjustable legs. Custom heights are available.



### Materials

**Support Base:** 17" circular base, injected molded polypropylene, with 227 sq. in. of surface on bottom, designed for weight displacement.

**Base Dimensions:** 3"H X 17" in diameter, designed for weight displacement, with molded insert for square tubing and two threaded rod couplings molded in.

**LEED:** Minimum 40 % post industrial recycled polypropylene with UV inhibitors.

**Frame:** 4"X4" Angle Iron ASTM 572, grade 50 and 1" X 3/16" bar grating, 19-W-4 carbon steel, ends capped with 1" X 3/16" steel flat bar, welded, hot-dip galvanizing after fabrication.

**Hardware:** Grating Clips with 1-1/2" Self Tapping Screws; 3/4" X 1-1/2" Bolts and 3/4" Nuts (used when additional platform sections are added) available in Hot-Dip Galvanized finish.

**Accessories:** Protection Pads

### **Installation:**

- A. Verify that roof surface is smooth and clean to extent needed to receive materials.
- B. Review approved final drawings to determine the locations of supports.
- C. Clean surfaces to receive supports removing any loose gravel and any foreign matter before setting support 17" circular bases.
- D. Accurately locate Base Platform in location specified as per approved shop drawings or as required herein and by site conditions. No Isolation pads are required under the 17" circular bases.
- E. Should the roofing manufacturer require a separation sheet between the roof and the support system, place a separation sheet or protective pad conforming to the existing roof manufacturer's system under 17" circular bases. Do not adhere to the roof system or 17" circular bases.
- F. Insert steel frame structures into 17" circular bases as indicated in above drawing.
- G. Adjust height of each support base for equal weight disbursement. Correct if necessary.
- H. Repeat until all support bases supplied are installed in accordance with approved shop drawings.
- I. Remove any unused materials and packaging from job site.

This print/image and design and detail shown hereon is the property of Advanced Support Products, Inc. This print is furnished with the understanding that it is not to be reproduced without permission, and must be returned upon demand. All rights of design and invention are reserved by Advanced Support Products.

Patents #5816554 ; #6229497; #6427965; #6448497; #6578827 © 2010